

★ AMERICAN GUNSMITH®

The Official Publication of The American Gunsmithing Association

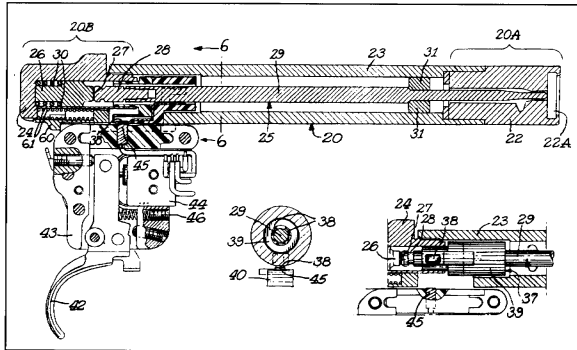

Remington EtronX...page 3



The 1911 Clones...page 8

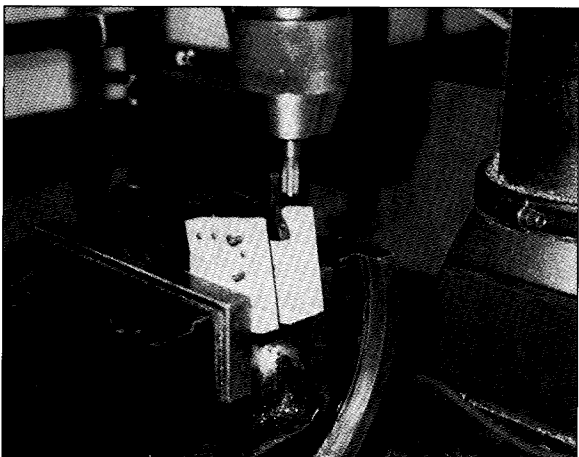

Easy Serrating and Checkering...page 20

3 An Overview of the Remington EtronX Electronic Rifle

Now available in three calibers—.220 Swift, .22-250, and .243 Winchester—Remington's EtronX may be the first successful "smart gun."

7 Will You Keep This Gun For Me?

Do you know your rights and responsibilities regarding the storage of personal guns in your shop?

8 The Age of the Clones: The Other 1911s

Although the venerable 1911 remains largely unchanged as it heads into its second century, there are important differences in the newer variations.

12 How to Build the Todd Crosshair Sight for Handguns

Here's a do-it-yourself alternative to the notch-and-blade handgun sight that rivals the electronic sight for accuracy and ease of use.

17 Microlon Gun Juice

This product claims to increase muzzle velocity, improve accuracy, and prevent corrosion. And guess what? It does.

20 Easy Serrating and Checkering

This inexpensive shop-crafted tool makes it easy to serrate and checker in your mill-drill.

2 The Editor's File

22 AGA News

23 Reader Forum

Microlon Gun Juice: Snake Oil For Guns or a Modern Miracle?

This product claims to increase muzzle velocity, improve accuracy, and prevent corrosion. And guess what? It does.

by Chick Blood

How many years ago was it? Andy Granatelli of turbine-engine Indy car fame used to take a screwdriver, dip it in STP, and defy anyone to hold onto the blade. Nobody could do it, because, in those days, STP contained molybdenum disulfide. As a compound, moly-di had a molecular structure that was like rolling thousands of very small, highly polished ball bearings between your fingers. No wonder it reduced friction in an engine.

More recently, moly-based protective coatings have been used on firearms. Now they're used on bullets. We don't know whether moly-di is an ingredient in Microlon Gun Juice. But we do know it's slippery.

Say what? You heard right...Microlon Gun Juice. It's never been advertised, but has literally traveled around the world by word of mouth as a friction reducer in racing cars and aircraft. The formula is secret, and has been for over 30 years.

How secret? When its inventor, a Texan named Bill Williams, was whipping up a batch, he did so with a pearl-handled .45 Long Colt on his hip and an armed guard at the door. Since its invention, several hundred industrial labs have tried to duplicate the formula without success, and an outfit or two have been successfully sued for claiming they had.

Williams' creation was actually inspired by his wife's desire to hunt with him. Being an extremely slight person, she couldn't withstand heavy recoil. The answer appeared to be a rifle chambered for a .17-caliber cartridge her husband designed and manufactured. In an interview held before his passing, Williams stated: "It got out there at extreme velocity, 7000 feet per second, but it burned out the barrel after 100 rounds." And so began his search for a rifle-barrel coating that would prevent carbon buildup and reduce friction.

His knowledge of chemistry convinced Williams that Teflon alone wouldn't stand up to the 52,000 pounds of pressure and 7000 degree F temperatures. Teflon liquefies at about 725 degrees and becomes a gas at 775 degrees. But he also knew there was nothing more slippery than rubbing two pieces of Teflon together, so he gathered some TFE resins, a few other substances and began experimenting.

One hundred and twenty seven formulas later: Eureka! A rifle treated with Williams' mixture fired 26,000 rounds of the .17-caliber ammo without the rifling showing any measurable wear and without accuracy being affected. A U.S. Army machine gun similarly treated allowed the weapon



Above: Many other manufacturers and laboratories have tried to duplicate the very secret formula that is Microlon Gun Juice, but none have come close, and a few have been successfully sued for falsely or erroneously claiming they had.

to function perfectly beyond "cook-off" temperatures—which automatically ignite a round when it's chambered into the overheated breech.

So just what is Williams' magic potion? It's the smoothest dry-film lubricant known. It is inert, will not wear off, and can only be removed by machining or elevating the temperature of a treated part to at least 775 degrees. When unburned powder and other byproducts of firing appear in a treated gun barrel, they are removed with a bit of solvent and patching.

That's it. No oil is called for or needed, and the permanent dry film

won't attract dirt, dust, or grease.

How Do You Use It?

Secure the gun in a bench rest. Wet a patch with Gun Juice, and pull it through the bore between the firing of each round. The product will clean the bore as it penetrates. When the point of impact stops rising on the target, the film has completely formed in the barrel.

As for the rest of the gun, polish its moving parts using a soft cloth moistened with Gun Juice. Allow the parts to air dry or accelerate the drying process with a hair dryer. Repeat the application and drying four times. On reassembly, you'll notice how much smoother the action operates. It will stay that way.

We've often advised *American Gunsmith* readers that the simplest, safest route to a decent trigger job is the reduction of friction. Gun Juice seems the easiest way to accomplish that.

Okay, Let's Check It Out

No mercy and no quarter asked or given. I took the first rifle I ever owned—a Winchester Model 60A given to me by my Dad in 1935—a box of standard-velocity .22-caliber ammo, an Oehler chronograph, a Decker rifle vise, and a 25lb bag of #7-1/2 lead shot to the range.

I'd knocked down my first tin can with that little Winchester. I'd taken squirrel and partridge with it in Maine, and rabbit in New Jersey before that state became a border-to-border housing development and hunting with a rifle was outlawed. The rifle has always been cared for, accurate, and still carries a good bore in spite of the rounds put through it over 65 years.

During a previous range session, this same ammo had tracked at an average of 1145 fps, but that was in another rifle. Five shots at nothing but

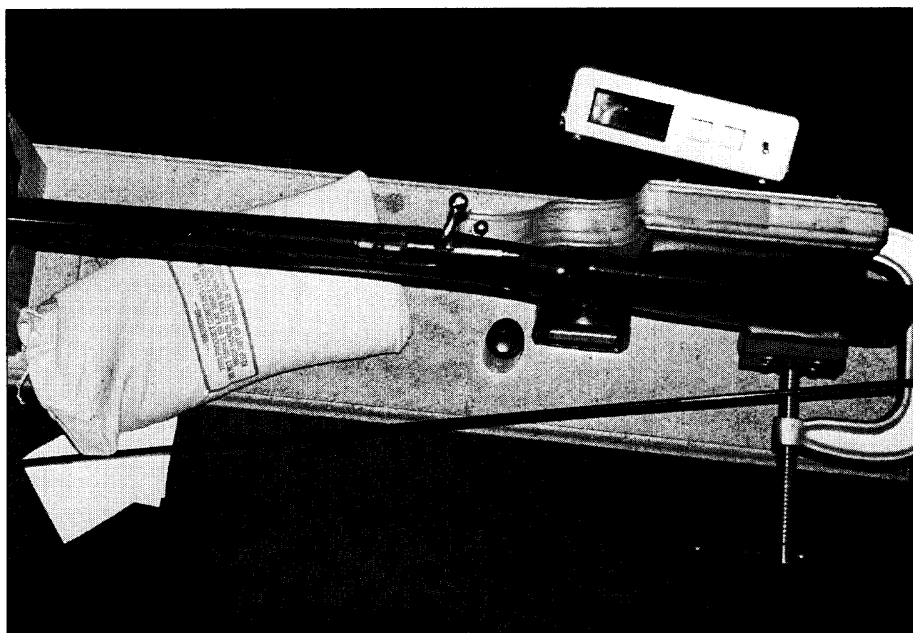

Above: Elements of the test are shown above: My first rifle, a Decker rifle vise, a 25-pound bag of #7-1/2 lead shot, Gun Juice, the read-out end of an Oehler chronograph, patches, and a Dewey cleaning rod. Not shown, 50 rounds of standard-velocity .22 ammunition with 40-grain, copper-plated heads.

a dirt embankment from the Model 60A worked out to 1140 fps. Next, I ran a patch wet down with Gun Juice from breech to muzzle, then benched and bagged it to line up its iron sights with a target of my own design. I've used this target often to fire test groups before returning guns to their owners.

As you can see, it ain't fancy. Just a simple square surrounding crosshairs. When the gun being checked out is scoped, I make sure the crosshairs on the target are perpendicular, and lay the scope's crosshairs on top of them. If the scope is electronic, the dot is placed on the intersection of the target crosshairs. For open sights, I rotate the square to the right or left and form a diamond. The front sight is aligned with the diamond's upper and lower points.

Of course, the borders of the square and the crosshairs get thicker as the range increases. The basic design

works just fine from 25 out to 100 yards, and I can Xerox as many copies as needed. Feel free to copy it for your own use. Moral: no more targets to buy for range testing.

The investigation continued at 50 yards as prescribed by the makers of Gun Juice. After the first round was away and chronographed, I ran another patch wet with Williams' secret formula through the bore, chambered another round, fired, and checked the velocity read-out. Then I wet patched, chambered a third round, fired, read the data, and wet patched again.

The second round impacted above the first, the third above the second, the fourth above the third, the fifth above the fourth, and the sixth next to the fifth. That's two more wet patches and firings than anticipated, but I wasn't going to stop until those little 40-grain pellets started hitting the

paper in the vicinity of each other. With no additional wet parching and a fresh target, a 10-shot group formed a 7/8-inch cluster, and muzzle velocity had risen by 90 fps, which meant my standard .22 ammo was now traveling at close or equal to high-velocity rates.

Just for the heck of it, I put up a few more targets, secured the rifle in the Decker vise, and fed another 20 rounds through it. The velocity was maintained; the accuracy remained un-

changed; and the bore swiped brightly clean.

The rifle will remain as the patriarch of my Winchester collection, and a bottle of Gun Juice will be added to my range gear as standard equipment.

Maybe a second bottle will hang out in my

shop for slicking up some of the actions that come my way. It could save me a lot of money on trigger/hammer stones. ■

Right: The basic design of the author's test target is a 2-1/2-inch square built around drawn-in crosshairs. The squares' borders and the crosshairs can be made heavier for better visibility at longer ranges. Feel free to photocopy the target if you wish to use it in your own testing. **Below left:** Here, you can see how the first round (a) impacted with additional rounds rising to the fifth and sixth round (b). At this point, the bore had been dry lubed and no further application of Gun Juice was required. **Below right:** Another target shows the 10-shot, 7/8-inch group fired after the muzzle velocity had increased by 90 fps through the treated bore.

